

3 ROLL OFFSET TROUGHING IDLERS

SERIES 25 - 127 DIA. ROLLERS - 20° / 35°

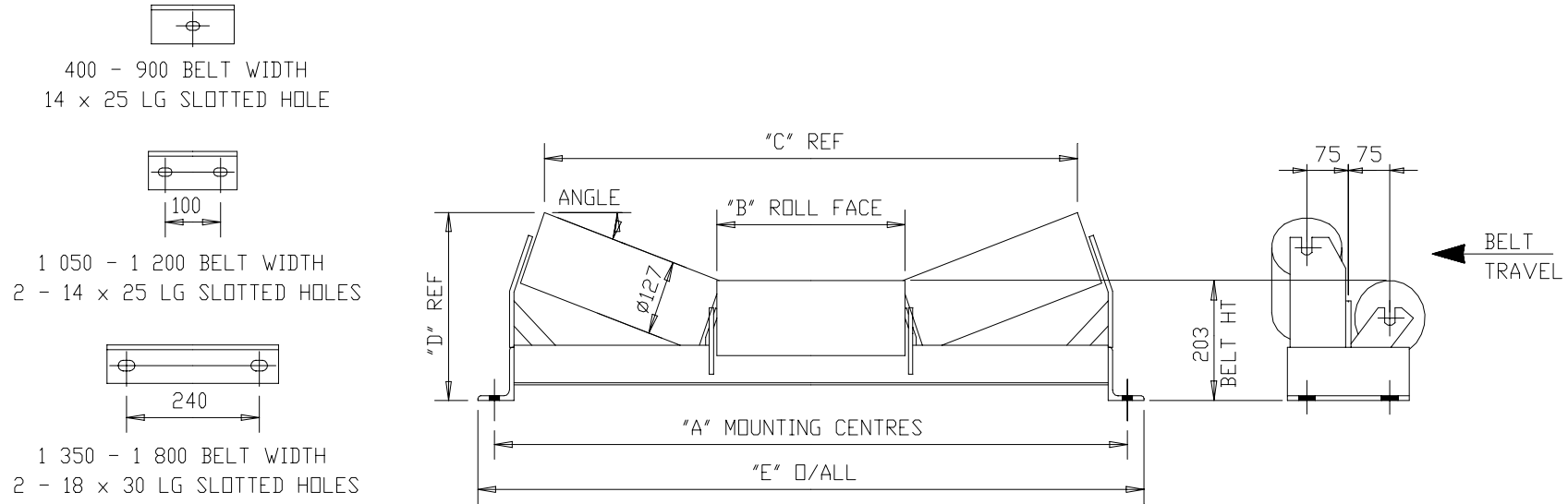

CONVEYOR EQUIPMENT



BELT WIDTH (mm)	A (mm)	B (mm)	C (mm)		D (mm)		E (mm)	BASE MASS (Kg)		ROLL MASS (Kg)	ROTATING MASS (Kg)	IDLER MASS (Kg)	
			20°	35°	20°	35°		20°	35°			20°	35°

400	634	170	470	430	259	298	694	6.60	7.33	4.11	3.21	18.92	19.65
450	686	190	528	483	266	310	746	6.83	7.56	4.41	3.44	20.07	20.80
500	736	200	556	509	270	315	796	7.03	7.70	4.57	3.56	20.73	21.40
600	838	240	672	615	284	338	898	8.03	9.17	5.18	4.02	23.58	24.72
750	990	290	816	748	302	366	1050	9.68	10.98	5.95	4.60	27.54	28.84
900	1144	340	960	878	318	395	1204	10.85	12.00	6.72	5.17	31.02	32.17
1050	1296	390	1104	1011	335	424	1356	13.58	14.56	7.49	5.75	36.06	37.04
1200	1448	450	1276	1170	356	458	1508	14.84	15.89	8.42	6.44	40.09	41.14
1350	1600	500	1420	1300	373	487	1660	20.68	22.56	9.19	7.02	48.24	50.12
1500	1752	560	1594	1459	393	522	1812	23.87	25.89	10.11	7.71	54.20	56.22
1650	1904	610	1736	1591	410	551	1964	25.29	27.53	10.88	8.29	57.93	60.17
1800	2058	660	1880	1723	427	579	2118	31.95	36.92	11.65	8.87	66.90	71.87